

1. INSPECTION AND PREPARATION OF THE SUBFLOOR

The product may be laid on the following subfloors:

- New or old subfloors such as:
 - Separate cement screeds or concrete slabs
 - Concrete paving
 - Intermediate and upper concrete slabs and floors
 - Cement or calcium sulphate-based liquid screeds
 - Asphalt concrete
 - Asphalt screed
- The following are also concerned:
 - Glued old sports floor coverings (PVC, rubber, resin, etc.)
 - Painted concrete
 - Old glued parquet flooring (in this case, do not use plastic film)

Local standards have to be applied and the following requirements must be satisfied:

- Surface evenness less than 5 mm when measured with a 2 m straightedge and 1 mm when measured with a 20 cm straightedge.
- Subfloor humidity less than 3 % at a depth of 2 cm using the carbide bomb meter test.
- The concrete must offer an average compressive strength of > 24.13 MPa after 28 days.

In the event of a nonconforming subfloor, it must be prepared in accordance with the product manufacturer's instructions.

2. PRODUCTS

NOTE : before you start work, check with our technical services whether this data sheet has been amended by a more recent version.

Examine the materials prior to installation to ensure that there are no visual defects. If the flooring has already been installed, the cost of any remedial work will not be covered.

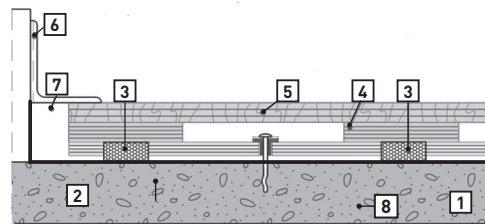
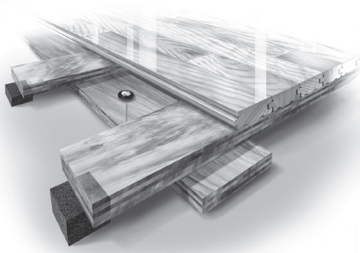

DESCRIPTION

1. Concrete slab
2. Polyethylene (0.15 mm)
3. Resilient pads 50 x 50 x 20 mm
4. Preassembled subfloor construction
5. Flooring
6. Vented cove base 76 mm x 102 mm
7. Expansion space (38 mm)
8. Anchor pin

3. SUBFLOOR CONSTRUCTION: FLOORING AND TOOLS

MATERIALS SUPPLIED WITH THE ORDER BY GERFLOR	MATERIALS AVAILABLE ON ORDER FROM GERFLOR	MATERIALS AND TOOLS SUPPLIED BY THE INSTALLER
FOR THE SUBFLOOR CONSTRUCTION		
		Staples 32 mm / 5,000 units / 1 box (900 m ²)
Preassembled subfloor construction / 1 panel = 3.34 m ² (spacing included)		Circular saw / jigsaw
	Vented cove base (1.22 linear metres) / 16 units	Electric screwdriver
Polyethylene 0.15 mm / 1 box (185.7 m ²)		Hammer drill
Anchor pins (three parts) / length 64 mm / diameter 6 mm / 8 per panel / 1 box (42 m ²)		Drill bit (6 mm)
Spacer wedge / thickness 6 mm (stop wedge)		Staple gun
		Hammer
		Wood adhesive sealant
FOR THE FLOORING		
Flooring bundles = 1.6 m ² / length from 0.23 m to 2.40m Width: 57 mm	For Alliance Staples 44 mm / 5,000 units / 1 box (60 m ²)	Staple gun, such as Bostitch MIIIFS, for fixing Connor flooring
		Shims
	Spline	Hammer
		Adhesive sealant

4. CONDITIONS AND PREPARATION OF THE GYMNASIUM

■ 4.1 - STORAGE

The materials required to install the ALLIANCE subfloor construction must be stored on site, in a dry area of the gymnasium that is protected from variations in temperature.

■ 4.2 - ACCLIMATISATION PERIOD

IMPORTANT : three days prior to installation, the ambient temperature in the room must be between 15 and 30°C. Relative humidity must be between 30 and 60 %. Once these conditions are met, all protective coverings and packaging can be removed to allow the materials to acclimatise. After unpacking, the materials must be left to rest for three days before installing.

While installing the subfloor construction, maintain the same conditions (i.e. ambient temperature from 15 to 30°C and relative humidity between 30 and 60 %). If there is any moisture in the room (such as a new build), you are advised to ventilate the room for four to six weeks before installing the subfloor construction. Ensure that the room is ventilated throughout installation.

5. LAYING THE POLYETHYLENE VAPOUR BARRIERE

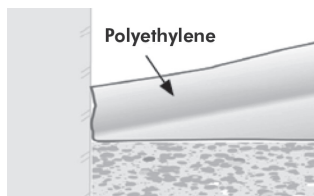

A polyethylene vapour barrier with a thickness of at least 150 microns must be laid across the entire subfloor.

Coving: the vapour barrier must be turned up at the edges of the room by at least 5 cm to reach the finished floor level. After woodfloor's installation, the vapour barrier must not be viewable. It may be cut if necessary.

Use of two vapour barriers: the barriers must overlap by 20 cm minimum. Overlaps are bonded using single-sided moisture-resistant adhesive tape and by width of 5 cm.

6. INSTALLING THE SUBFLOOR CONSTRUCTION

■ Cross-cut a starter panel into two equal halves (refer to the diagram).

Fix the blocks beneath the cut section.

Use the left section **1** to start the first row at the far end of the gymnasium.

Maintain a space of 38 mm between the subfloor construction and all the walls and vertical obstructions.

Support sleeper ends with solid blocking material. **4**

TIPS

Use offcuts from the subfloor panels to make blocks.

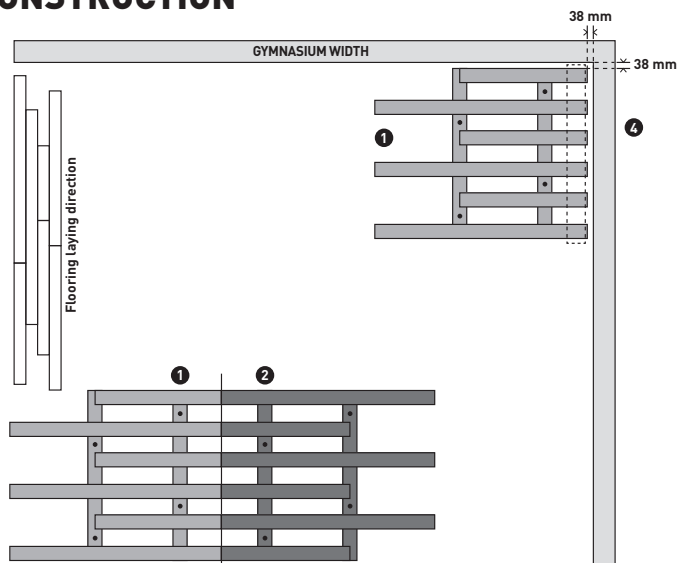

■ Continue the first row with full panels **3** and finish by trimming the last panel to fit the dimensions of the gymnasium.

Fix the subfloor construction elements together and maintain a space of 6 mm between the ends of the sleepers.

Sleeper ends must be fixed together using sealant and 32 mm staples fixed perpendicularly.

Anchor the subfloor construction as you go along: refer to Section 8, entitled «Anchoring the subfloor construction».

TIPS

Assemble panels together by slightly lifting the panel already on the floor. The second panel will slide in more easily underneath.

Place anchor pins (diam. 6) between the panels to maintain a 6 mm gap. Recover the anchor pins after fixing the subfloor elements together.

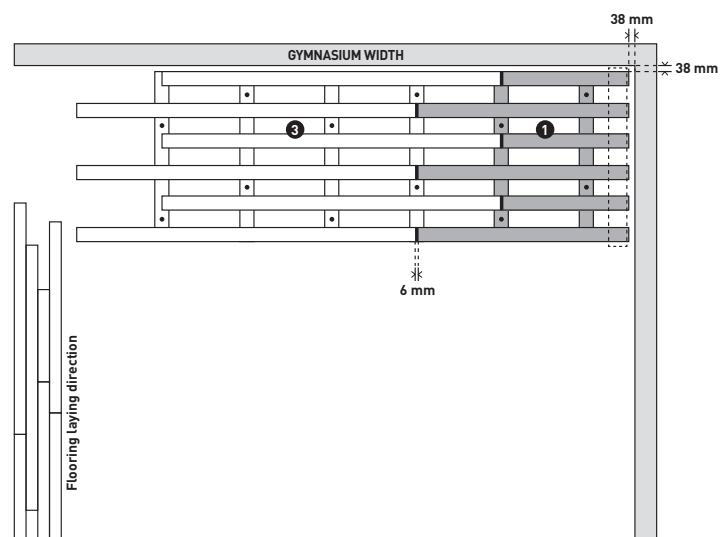

■ Start the second row by rotating the right end ② of the cross-cut panel before installing.

Provide the same spacing between each row as provided between the sleepers, **i.e. 121 mm.**

Continue the second row with full panels and finish by trimming the last panel to fit the dimensions of the gymnasium.

Anchor the subfloor construction: refer to Section 8, entitled «Anchoring the subfloor construction».

IMPORTANT

Do not start a new row with a panel offcut.

It is important to start each new row with a panel that has been cut in half. This will ensure that the fixing points are aligned on the floor and that the flooring will behave consistently across the entire surface.

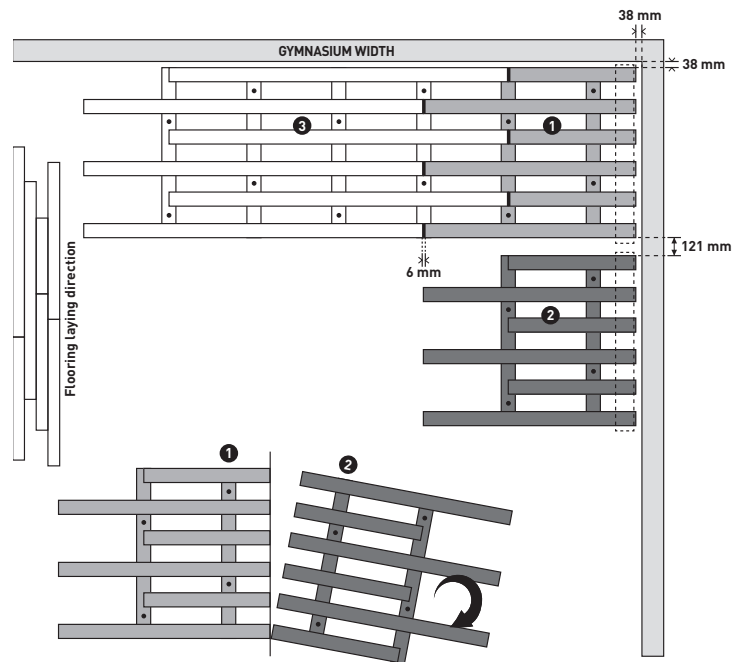

■ Continue installing rows in the same manner by cross-cutting a starter panel each time.

Maintain a space of 6 mm between each element of the subfloor construction.

Glue and staple the elements together and anchor to the ground as specified in Section 8.

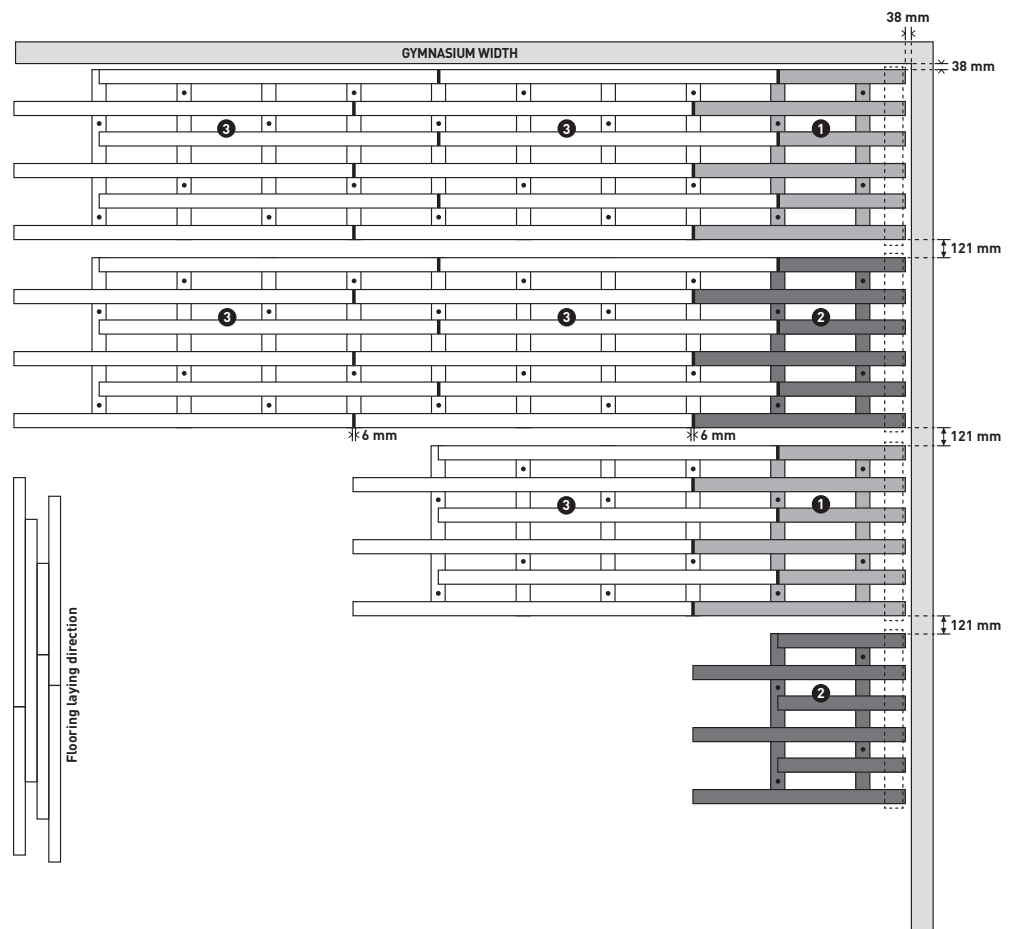

7. REINFORCEMENT BLOCKS TO BE INSTALLED BENEATH RETRACTABLE SEATING SYSTEMS IN THE STACKED POSITION, IN FRONT OF ACCESS DOORS, STORAGE AREAS, PORTABLE BASKETBALL STANDS, ETC.

Reinforcement blocks must be installed instead of pads in areas subject to high static loads and at sleeper ends (refer to Section 6). Remove the pads and screw the blocks into the subfloor construction.

TIPS

Use offcuts from the subfloor panels to make blocks.

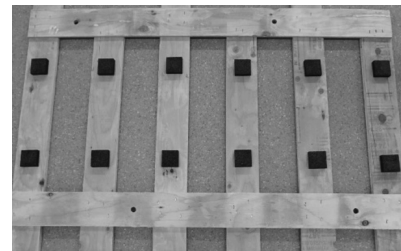
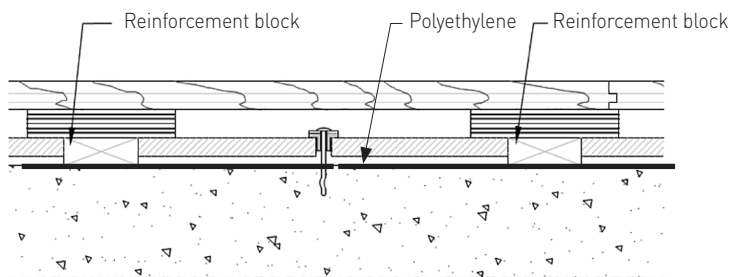

1. Remove the pads.
2. Replace with wooden blocks measuring 50 x 50 x 20 mm (thickness).

8. ANCHORING THE SUBFLOOR CONSTRUCTION

8.1 - DRILLING FOR THE ANCHOR PINS

Use a hammer drill and a 6 mm masonry drill bit. Drill through the pilot holes in the subfloor construction and the polyethylene. Drill depth through the subfloor construction = 70 mm

TIPS

Before drilling into the subfloor, place the bushing on the sleeper and use as a drilling guide.

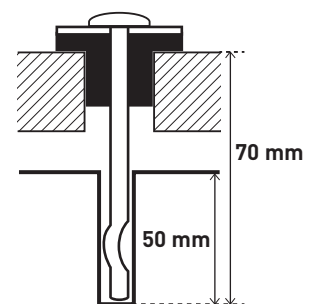

8.2 - FIXING THE ANCHOR PINS.

8.2.1 Preparing the anchor pins

Anchor pins are supplied in three parts. Place the washer with the rubber side up against the underside of the anchor pin head. This prevents the two metal parts from coming into contact and causing squeaking over time.

TIPS

Oil the end of the anchor pin, so that it will slide into the washer more easily.



1 - Anchor pin

2 - Washer to be fitted with the rubber side up

3 - Rubber bushing with the widest part facing up

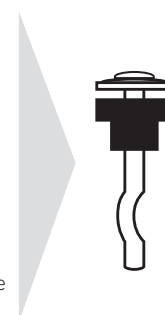

8.2.2 Installing the anchor pins

Before hammering the anchor pin through the subfloor construction, place the spacer wedge between the sleeper and the polyethylene to avoid driving the subfloor in too far.

The spacer wedge offsets the difference in thickness and allows the pad to perform its cushioning role.

The anchor pin has been driven in far enough when the washer no longer moves, but can still be rotated around the anchor pin if turned with two fingers. The bushing must not be crushed against the sleeper.



Place this wedge beneath the sleeper before hammering the anchor pin.

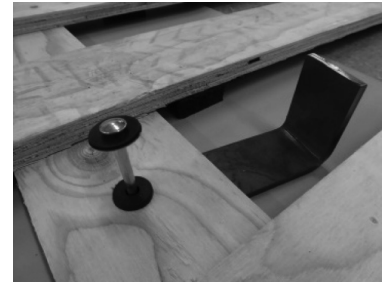

Hammer the anchor pin into place.

TIPS

If necessary, check that the anchor pin has been driven in far enough by measuring the space between the anchor pin head and the upper sleeper.



The block can pass through the gap between the anchor pin head and a panel placed on the upper sleepers.



Result to have

9. INSTALLING THE FLOORING

■ 9.1 - DEFINE THE EXPANSION GAPS

- After maple strips acclimatization period (§4.2), **realize moisture measurements** in the maple strips with a moisture indicator. Realize measurements using different maple strips bundles and in different localization in the bundles. The average value is your «maple moisture content during installation» (IMC).
- According to your **local area knowledge about maple moisture** value in time:
 - If you know the highest maple value you can reach, consider it as «maple moisture level during its life» (LMC)
 - If you know the facility will have a controlled environment including relative humidity between 35% and 50%, consider 9% as your «maple moisture level during its life» (LMC)
 - If you don't know the highest maple value you can reach, consider 13% as your «maple moisture level during its life» (LMC).
- Calculate the difference** between your value of «maple moisture level during its life» (LMC) and your value of «maple moisture content during installation» (IMC). We will call this result the "maple moisture content to cover" (MCC) -> **(MCC) = (LMC) - (IMC)**
- Define the expansion gaps.** According your "maple moisture content to cover" (MCC) value, you can define the expansion gaps to manage on the playground during the installation.

	EXPANSION GAP BETWEEN EACH STRIP	EXPANSION GAP EVERY 4 STRIPS	EXPANSION GAP EVERY 6 STRIPS	EXPANSION GAP EVERY 8 STRIPS
0% < MCC < 1%	0,07 mm	0,28 mm	0,42 mm	0,56 mm
1% < MCC < 2%	0,15 mm	0,60 mm	0,90 mm	1,20 mm
2% < MCC < 3%	0,20 mm	0,80 mm	1,20 mm	1,60 mm
3% < MCC	0,25 mm	1,00 mm	1,50 mm	2,00 mm

Values to consider for maple strip of 57 mm width.

For example, if MCC = 1,5%, you need to insure a gap of 0,60 mm every 4 strips or a gap of 0,90 mm every 6 strips using shims.

For aspect reasons:

- We recommend to realize expansion gaps under 1,50 mm,
- We recommend to provide smaller expansion gaps more frequently rather than wider expansion gaps in lower quantity.

■ 9.2 - INSTALLING THE FLOORING ON SLEEPERS

9.2.1 - INSTALLATION ALONG THE LONGITUDINAL AXIS

Install the flooring strips by starting in the middle of the gymnasium.

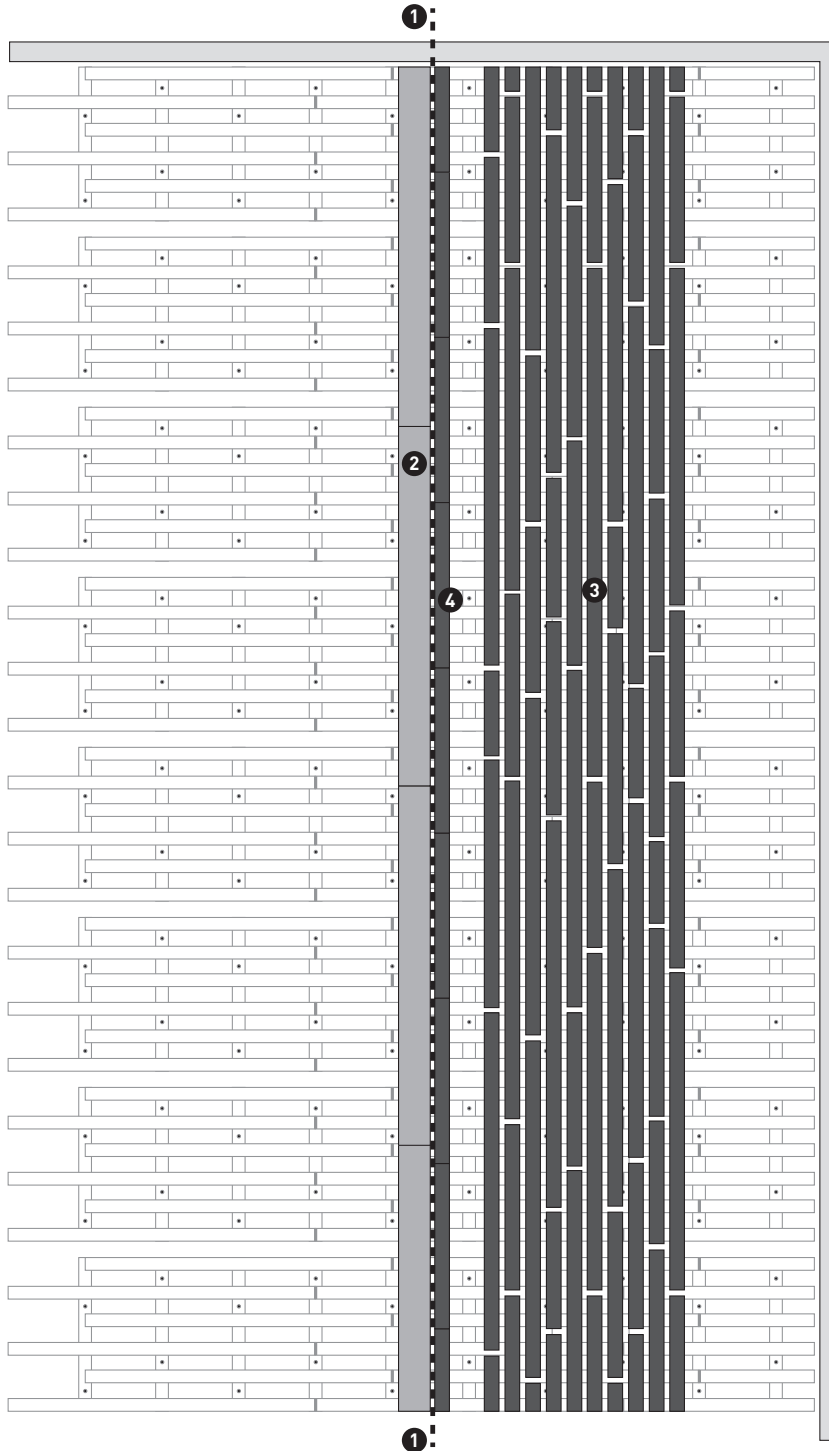

- 1 Mark out the longitudinal axis along the subfloor construction.
- 2 Provisionally fix plywood sheets along the longitudinal axis.
- 3 Present and sort the strips so that they are ready to be stapled according to the following rule:

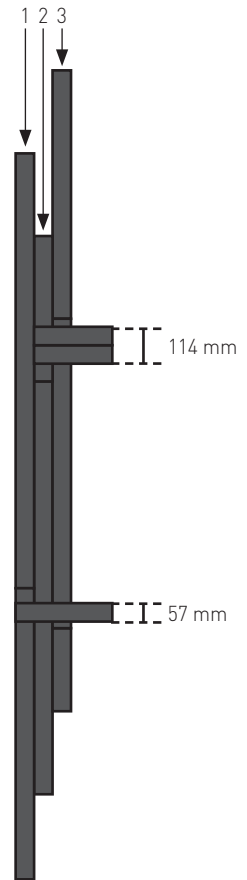

- The offset in joints between consecutive rows must be greater than 114 mm (width of two strips).
- The offset in joints between every other row must be greater than 57 mm (width of one strip).

- 4 Staple a row of strips along the axis using the plywood sheets as a guide.

Add shims according to value you define using §9.1

Don't remove a line of shims before the realisation of a new line of shims



TIPS

To have shims easy removal:

- Be sure to respect the pressure recommendation of your staple gun.
- Remove your expansion gaps blocks at least at the end of the day.

9.2.2 - INSTALLING THE SECOND HALF OF THE GYMNASIUM

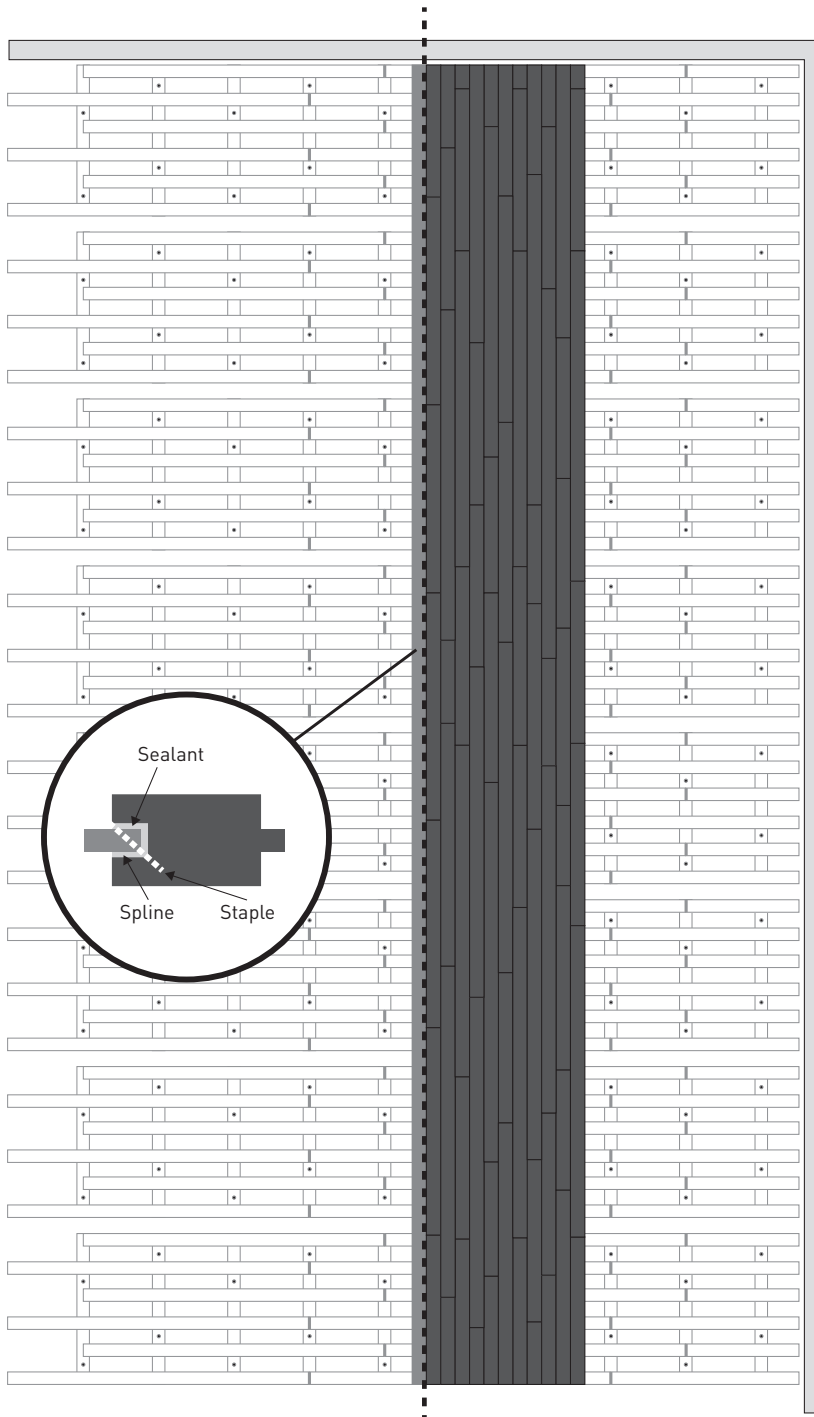

Fixing the spline



Applying the spline in the groove of the strips along the longitudinal axis:

- Remove the plywood sheets.
- Apply adhesive sealant to the bottom of the groove.
- Gently tap the spline into place using a hammer.
- Staple the spline to the flooring.

■ 9.3 - FIXING THE STRIPS

Connor flooring strip joints do not always fall on a sleeper ①

9.3.1- Installation

Strips must be stapled with a staple gun, such as Bostitch MIIIIFS (www.bostitch.fr).

Recommendations for Alliance:

Staple the flooring strips to each sleeper.

Do not staple less than 3 cm from the end of a strip.

TIPS

To ensure the proper functioning of the staple gun:

- Be careful to respect the pressure recommendation
- Use and add lubricant preconised by the staple gun provider every day of working.

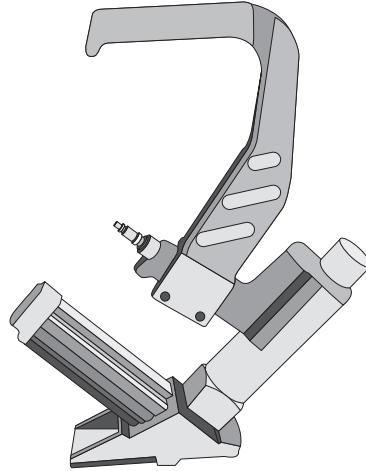

9.3.2 - Finishes

9.3.2.1. Installing edging strips

The last rows of strips that cannot be stapled must be glued in the tongues and grooves. Use a pull bar to fit the last row, which will have been previously cut (using a marking gauge).

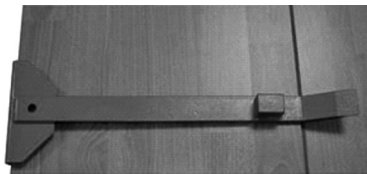

9.3.2.2. Peripheral expansion

- If installing on panels, leave a 38 mm expansion void at the perimeter.

10. SANDING, SEALING AND PAINTING CONNOR FLOORING

GERFLOR validated the sanding and sealing associated with BLANCHON, BONA and POLOPLAZ suppliers.

Depending on the products used, refer to the corresponding Installation guideline.

